

2026-03-16 FanEnd+Blower+ThermalBreak_V16 / PLC_1 [CPU 1215C DC/DC/DC] / Program blocks

Acknowledgement Button [FB1]

Acknowledgement Button Properties

General					
Name	Acknowledgement Button	Number	1	Type	FB
Numbering	Automatic	Language	LAD		
Information					
Title		Author		Comment	
Version	0.1	User-defined ID		Family	

Acknowledgement Button

Name	Data type	Default value	Retain	Accessible from HMI/OPC UA/Web API	Writ-able from HMI/OPC UA/ Web API	Visible in HMI engi-neering	Setpoint	Supervi-sion	Comment
Input									
Output									
InOut									
Static									
Temp									
Constant									

Network 1: PB LED

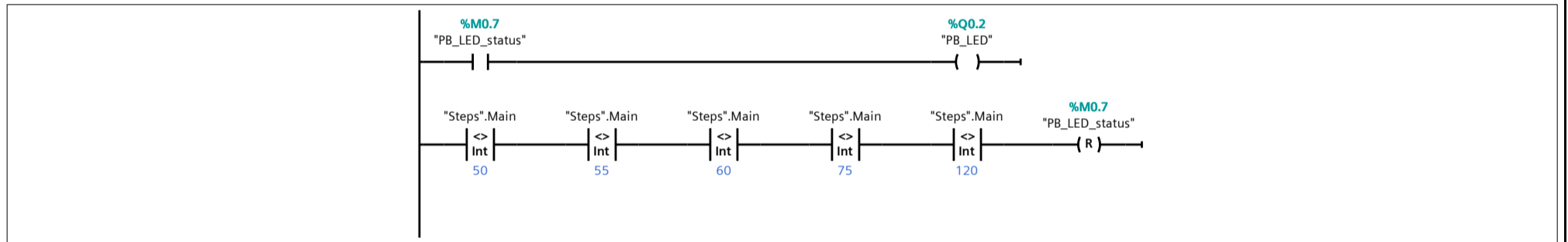

Network 2: Step 4 - secure speed sensor wires

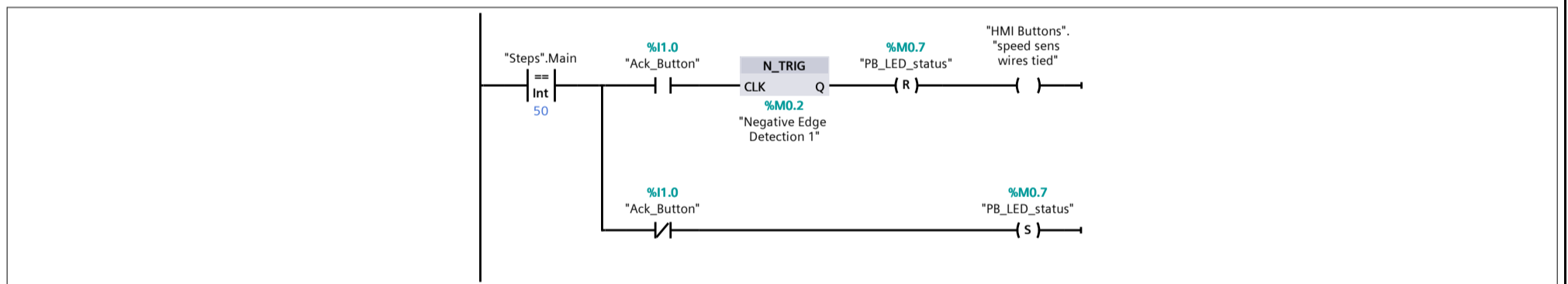

Network 3: Step 5 - connect speed sensor wires

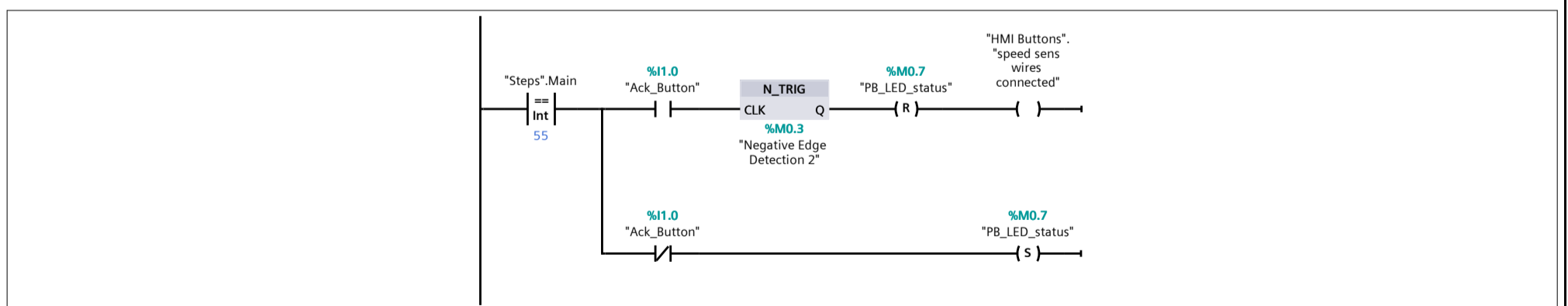

Network 4: Step 6 - install seal looms and boots on ignitial module

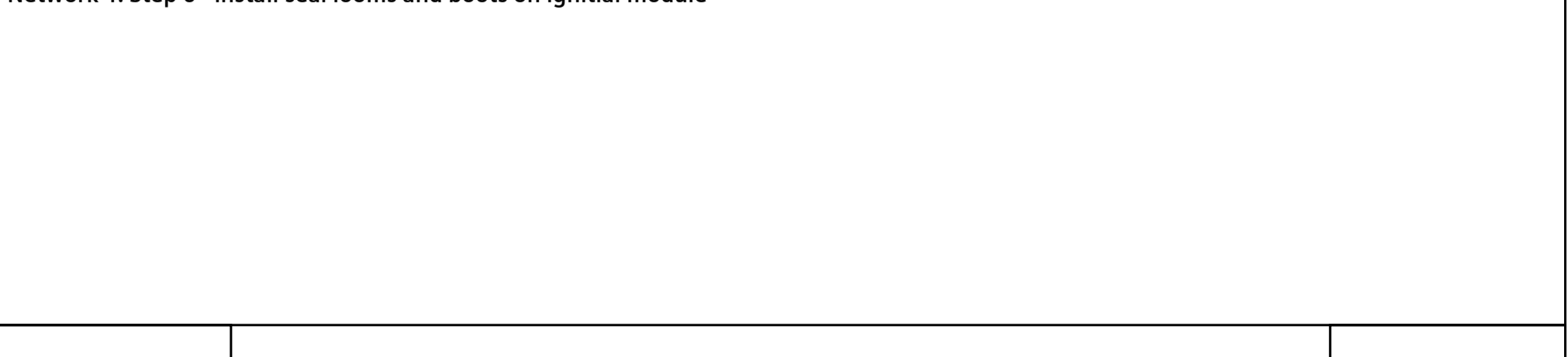

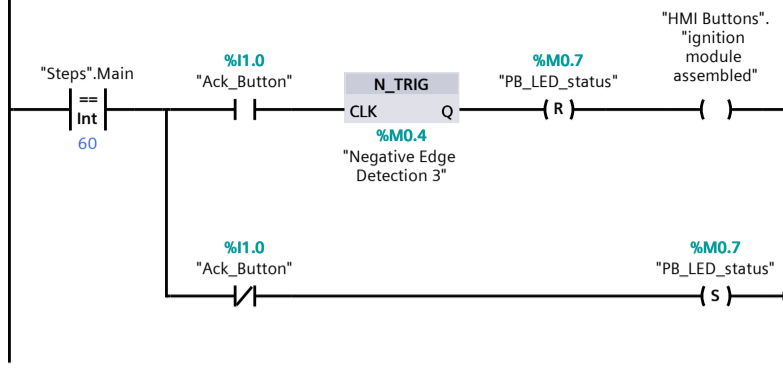

Network 5: Step 8 - connect and set diffuser cone

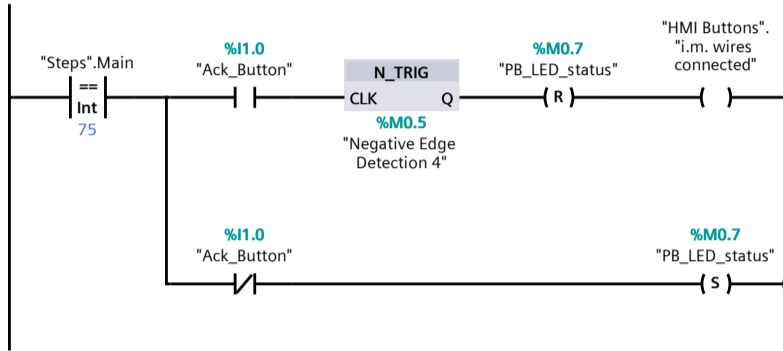

Network 6:

