

## Misc\_Cyl\_Assembly\_rev3 / PLC\_1 [CPU 1215C DC/DC/DC] / Program blocks / Calibration

### Calibrate\_Specific [FB9]

#### Calibrate\_Specific Properties

##### General

Name	Calibrate_Specific	Number	9	Type	FB	Language	LAD
Numbering	Automatic						

##### Information

Title		Author		Comment		Family	
Version	0.1	User-defined ID					

#### Calibrate\_Specific

Name	Data type	Default value	Retain	Accessible from HMI/OPC UA/Web API	Writable from HMI/OPC UA/Web API	Visible in HMI engineering	Setpoint	Supervision	Comment
Input									
Output									
InOut									
▼ Static									
Calibration_Specific_steps	Int	0	Non-retain	True	True	True	False		
Actuator_Type	Int	0	Non-retain	True	True	True	False		
▼ Timer	IEC_TIMER		Non-retain	True	True	True	False		
PT	Time	T#0ms	Non-retain	True	True	True	False		
ET	Time	T#0ms	Non-retain	True	False	True	False		
IN	Bool	false	Non-retain	True	True	True	False		
Q	Bool	false	Non-retain	True	False	True	False		
Temp									
Constant									

#### Network 1: choose specific actuator to calibrate

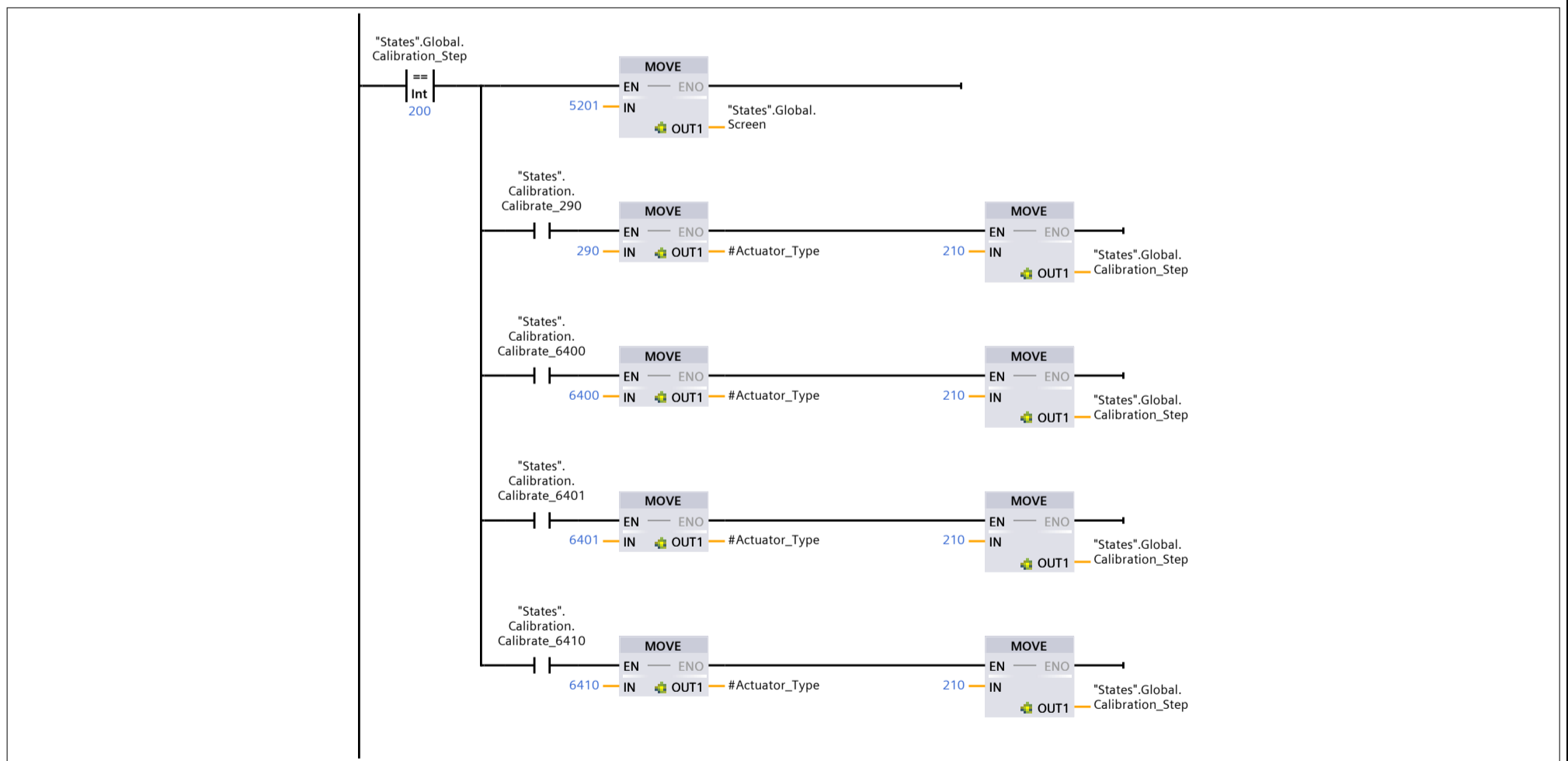

#### Network 2: Home Clamps

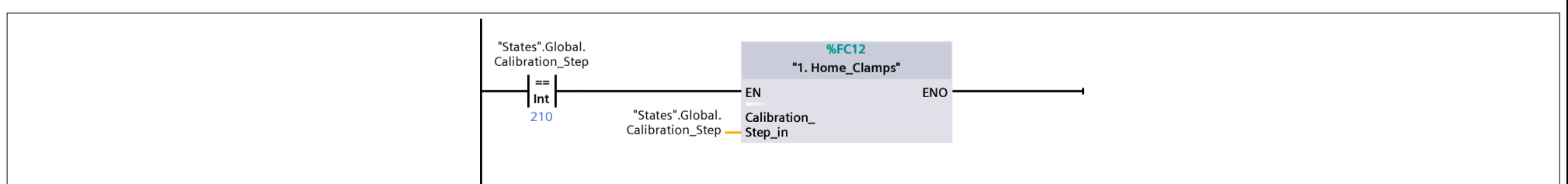

#### Network 3:

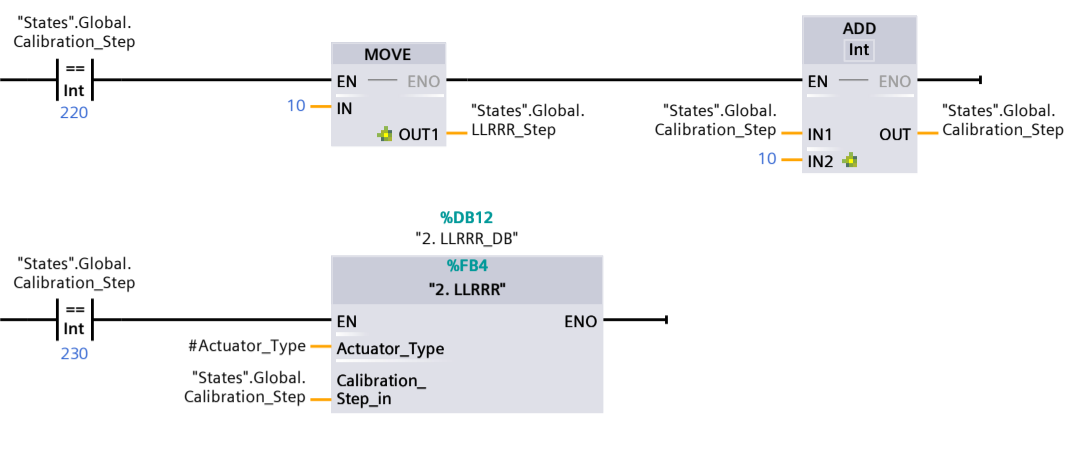

Network 4:

