

X30_Compressor_Press_rev5 / PLC_1 [CPU 1215C DC/DC/DC] / Program blocks

BEARING_PRESS [FC1]

BEARING_PRESS Properties

General

Name	BEARING_PRESS	Number	1	Type	FC	Language	LAD
------	---------------	--------	---	------	----	----------	-----

Numbering	automatic
-----------	-----------

Information

Title		Author		Comment		Family	
-------	--	--------	--	---------	--	--------	--

Version	0.1	User-defined ID	
---------	-----	-----------------	--

BEARING_PRESS

Name	Data type	Default value	Comment
Input			
Output			
InOut			
Temp			
Constant			
Return			
BEARING_PRESS	Void		

Network 1: loctite application

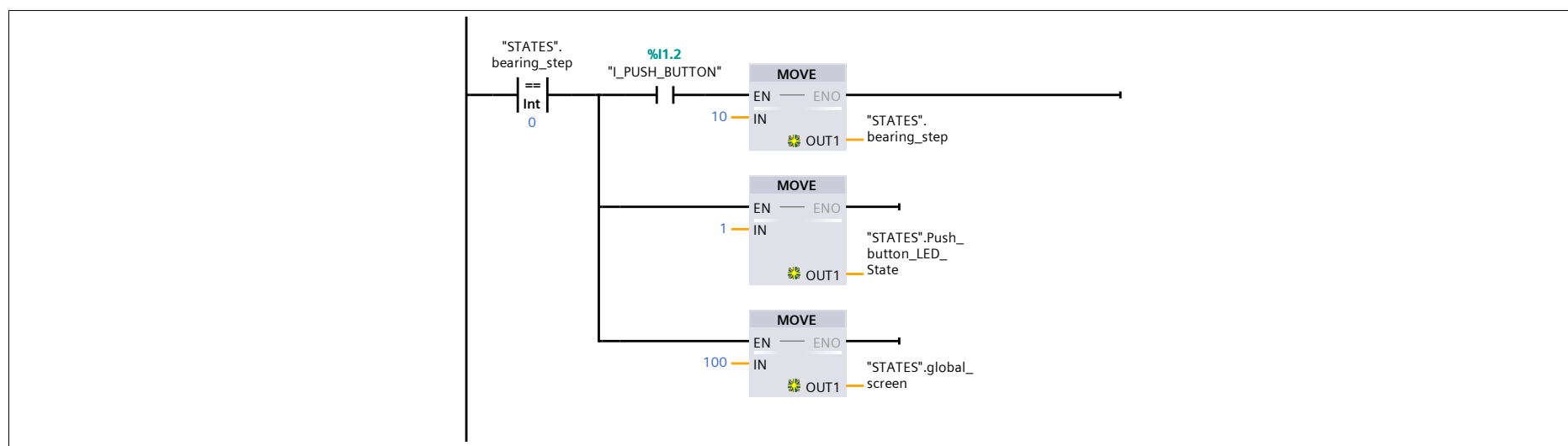

Symbol	Address	Type	Comment
"L_PUSH_BUTTON"	%I1.2	Bool	
"STATES".bearing_step		Int	
"STATES".global_screen		Int	
"STATES".Push_button_LED_State		Int	

Network 2:

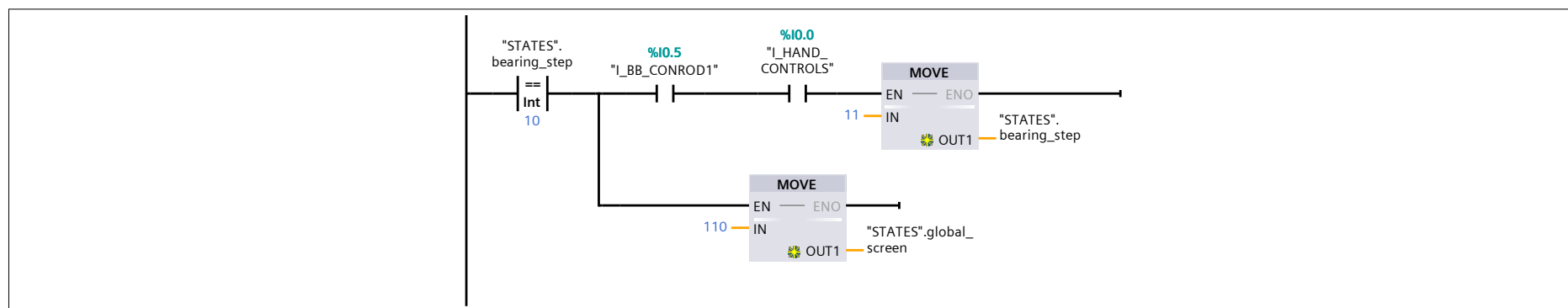

Symbol	Address	Type	Comment
"L_BB_CONROD1"	%I0.5	Bool	
"L_HAND_CONTROLS"	%I0.0	Bool	
"STATES".bearing_step		Int	
"STATES".global_screen		Int	

Network 3: Press stroke

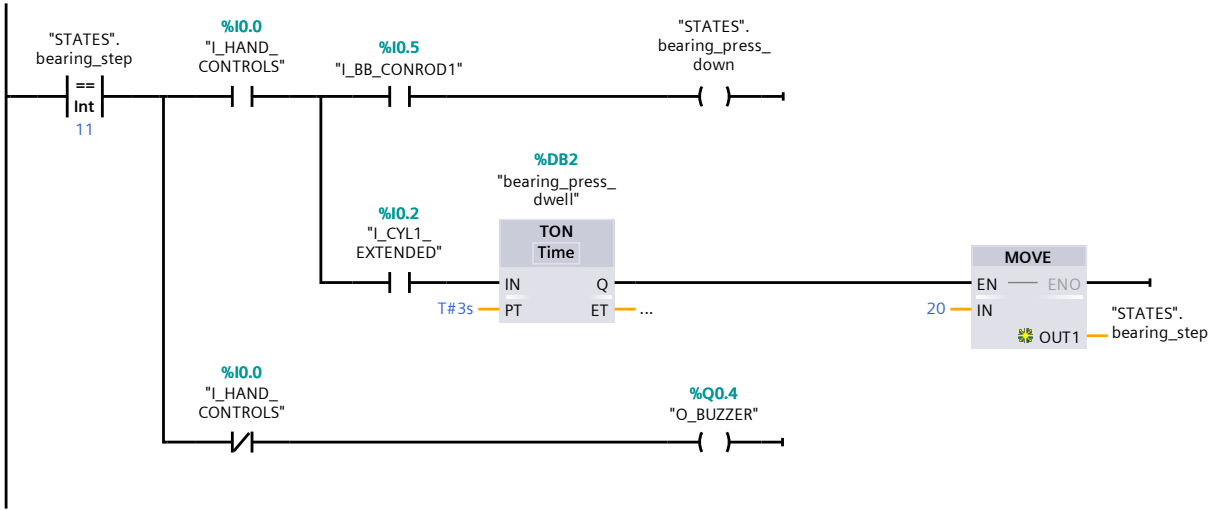

Symbol	Address	Type	Comment
"I_BB_CONROD1"	%I0.5	Bool	
"I_CYL1_EXTENDED"	%I0.2	Bool	
"I_HAND_CONTROLS"	%I0.0	Bool	
"O_BUZZER"	%Q0.4	Bool	
"STATES".bearing_press_down		Bool	
"STATES".bearing_step		Int	

Network 4: Pressure check

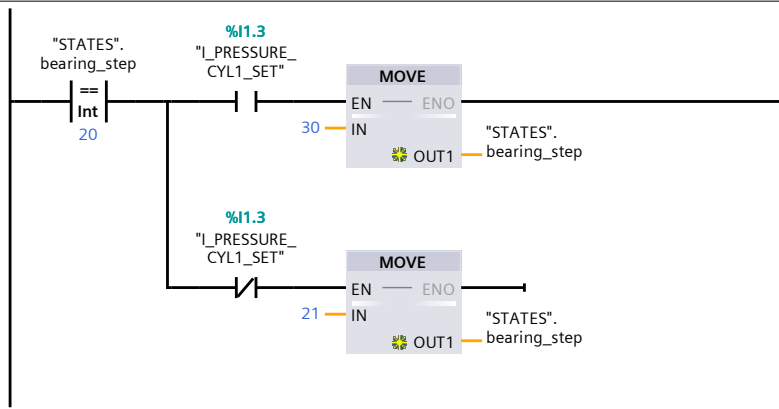

Symbol	Address	Type	Comment
"I_PRESSURE_CYL1_SET"	%I1.3	Bool	
"STATES".bearing_step		Int	

Network 5: FAULT: insufficient pressure

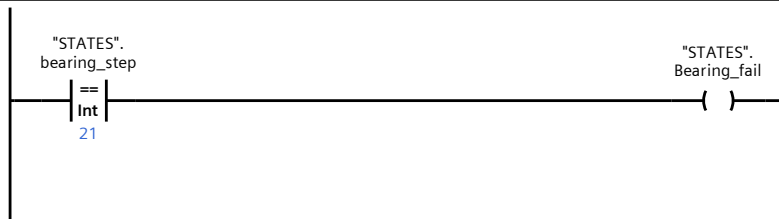

Symbol	Address	Type	Comment
"STATES".Bearing_fail		Bool	
"STATES".bearing_step		Int	

Network 6: press successful

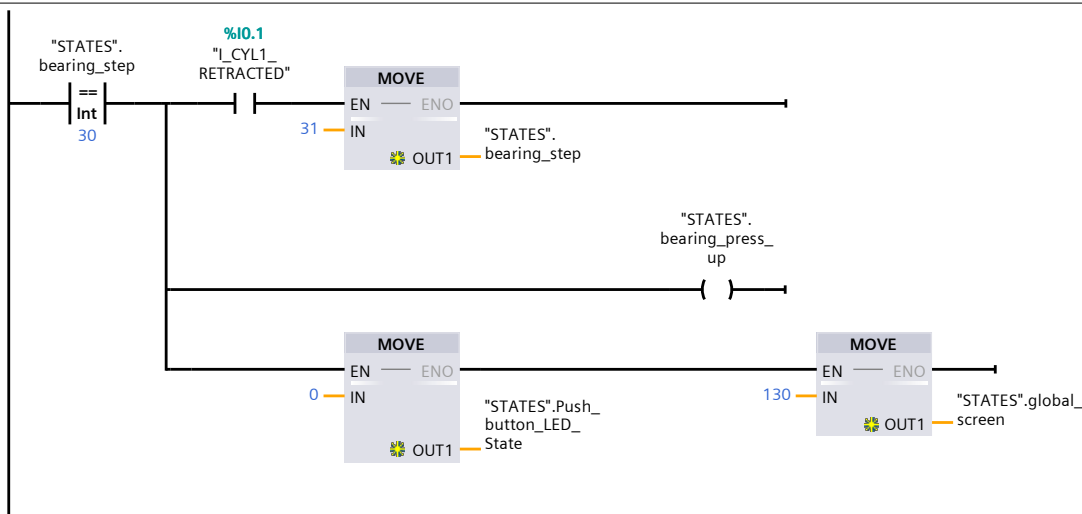

Symbol	Address	Type	Comment
"I_CYL1_RETRACTED"	%I0.1	Bool	
"STATES".bearing_press_up		Bool	
"STATES".bearing_step		Int	
"STATES".global_screen		Int	
"STATES".Push_button_LED_State		Int	

Network 7:

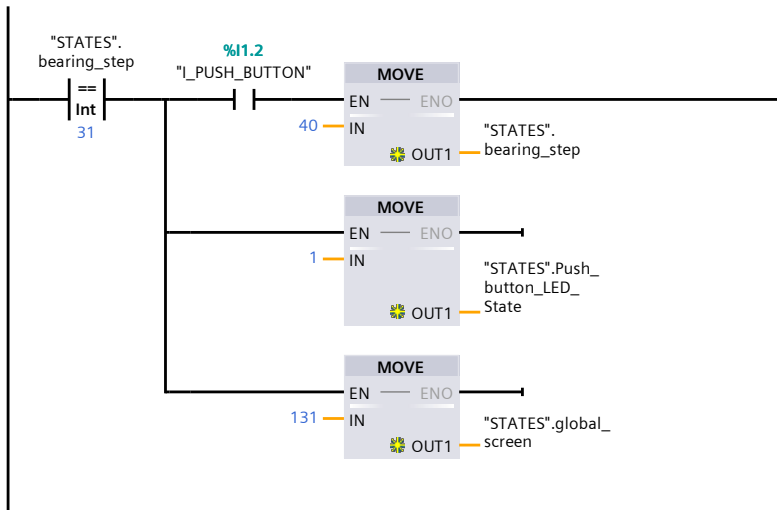

Symbol	Address	Type	Comment
"I_PUSH_BUTTON"	%I 1.2	Bool	
"STATES".bearing_step		Int	
"STATES".global_screen		Int	
"STATES".Push_button_LED_State		Int	

Network 8: remove conrod

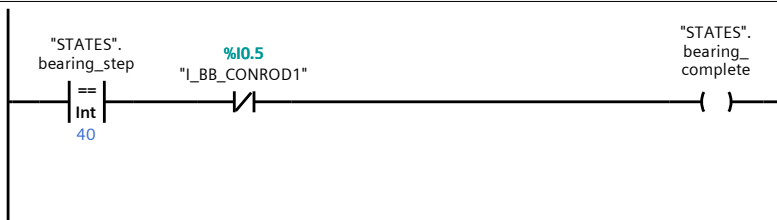

Symbol	Address	Type	Comment
"I_BB_CONROD1"	%I0.5	Bool	
"STATES".bearing_complete		Bool	
"STATES".bearing_step		Int	

Network 9:

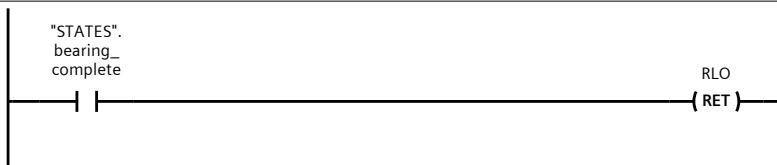

Symbol	Address	Type	Comment
"STATES".bearing_complete		Bool	