

Name	Data type	Default value	Retain	Accessible from HMI/OPC UA/Web API	Writable from HMI/OPC UA/Web API	Visible in HMI engineering	Setpoint	Supervision	Comment
norm_val	Real								
Constant									

Network 1: Establish condition thresholds

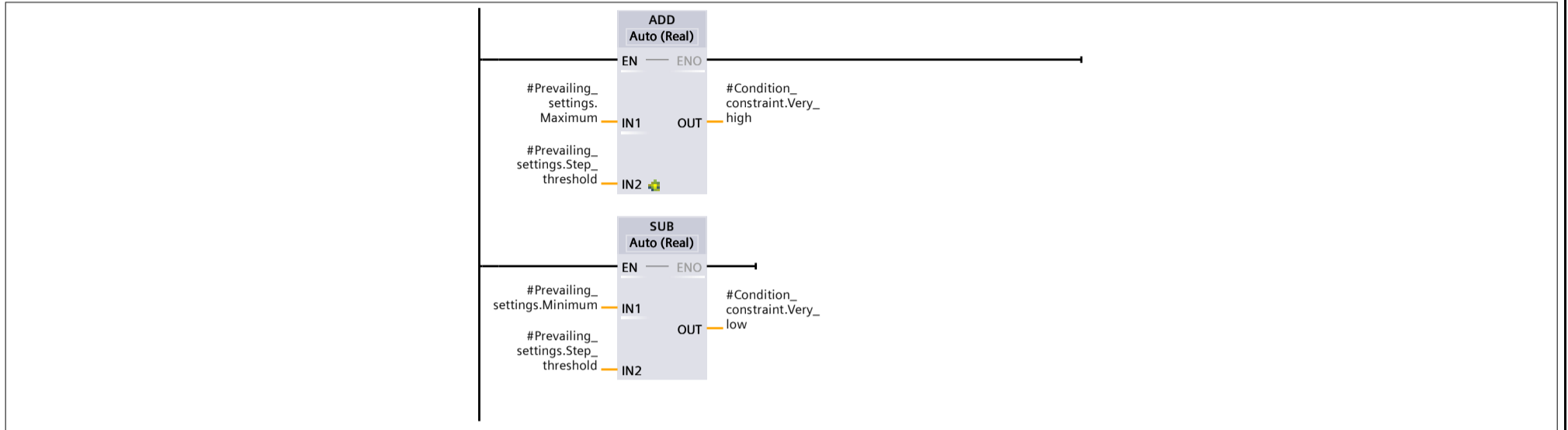

Network 2:

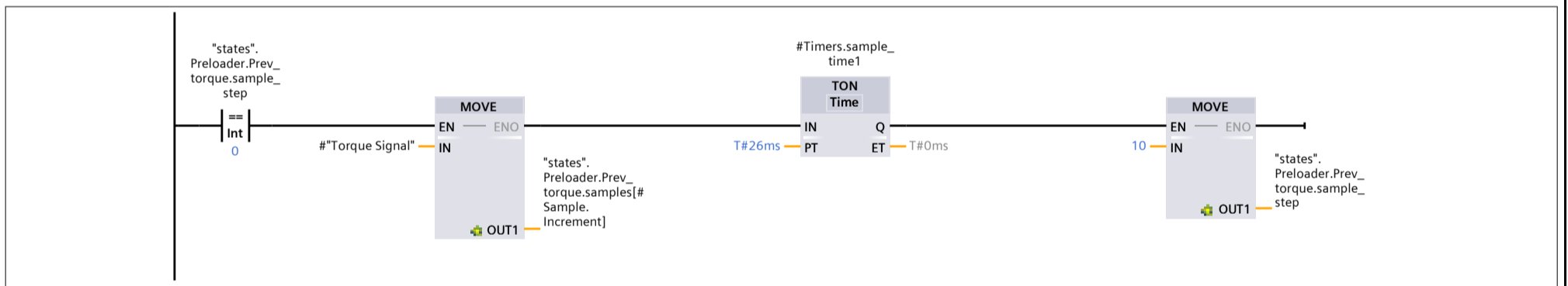

Network 3:

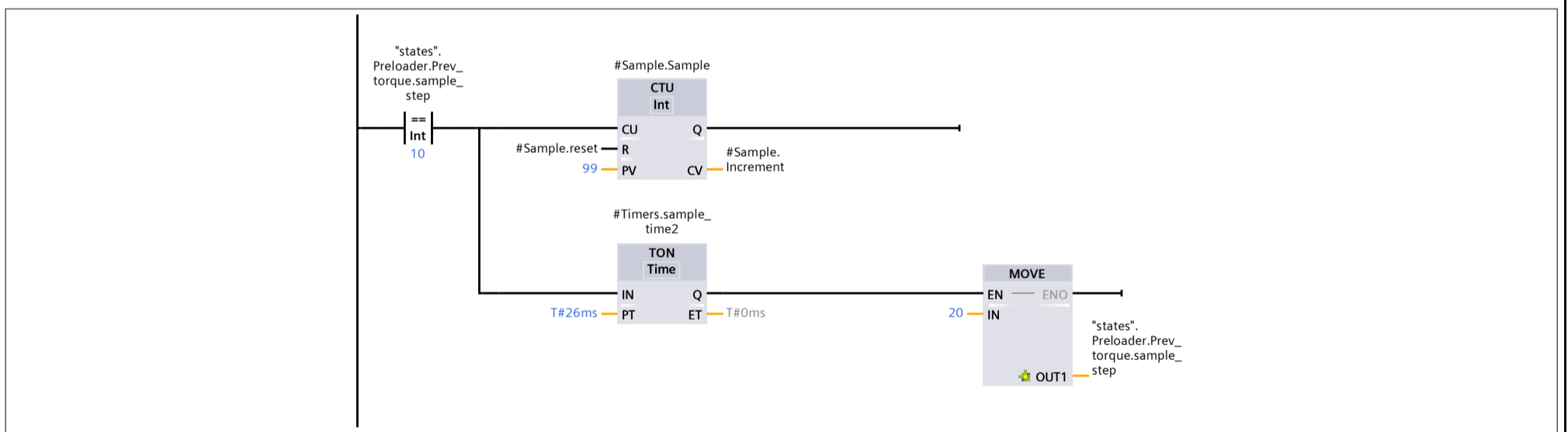

Network 4:

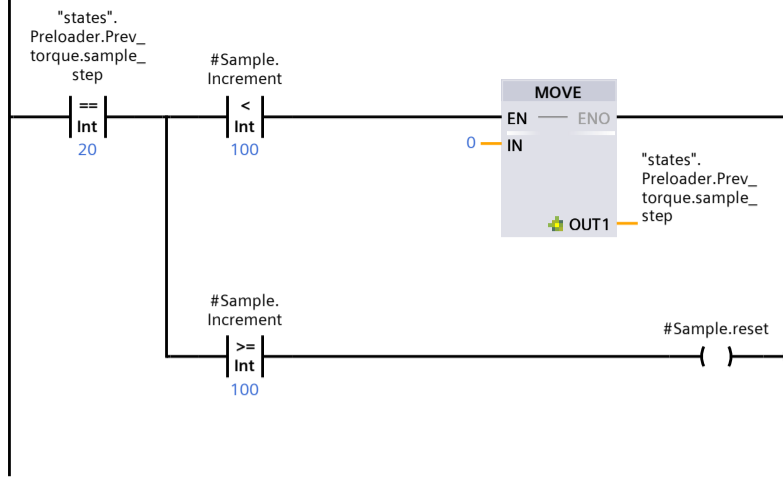

Network 5:

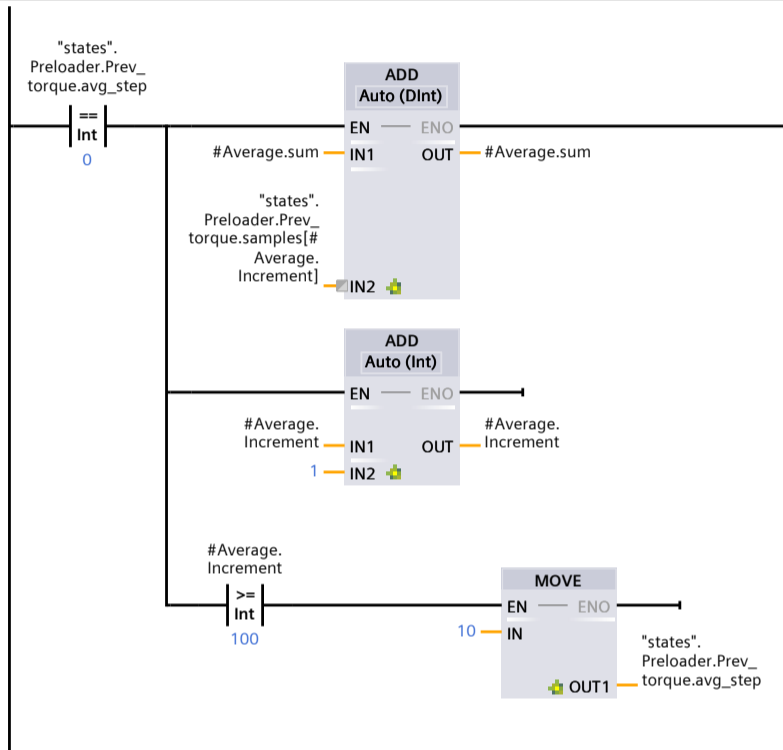

Network 6:

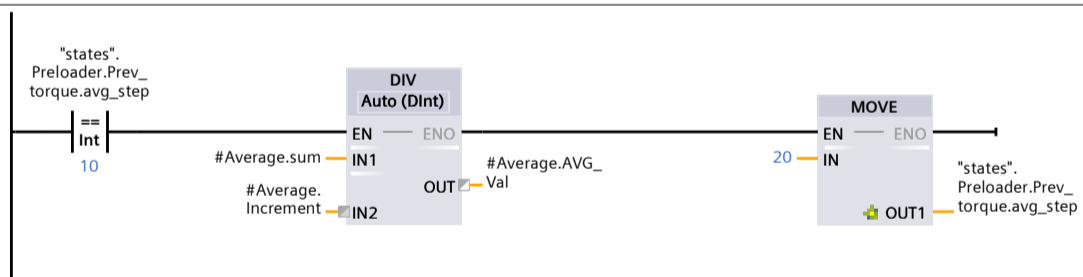

Network 7:

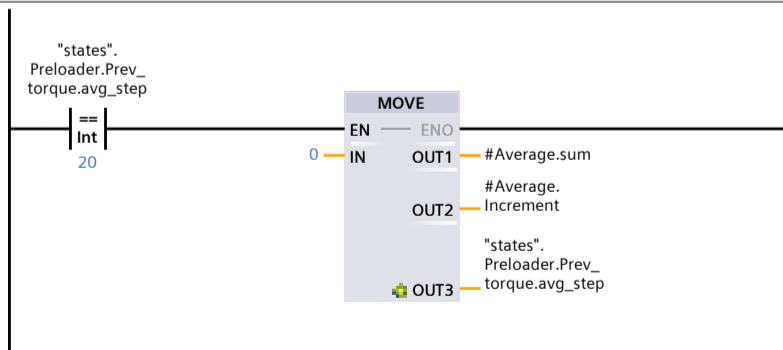

Network 8:

scale average value of raw current to torque by using $y=mx+b$ where
 y = torque = average out
 x = average raw
 m = slope
 b = offset

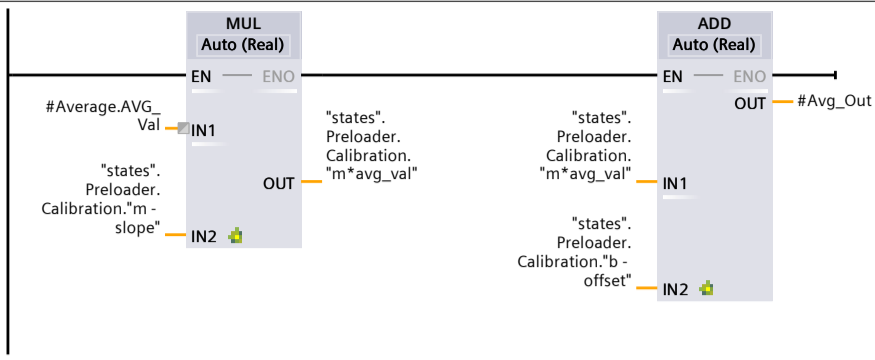

Network 9: Torque_condition

